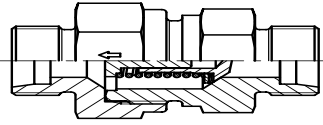
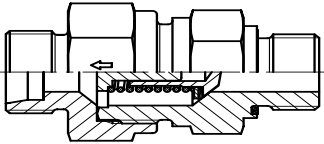
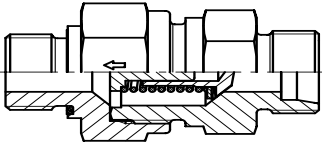
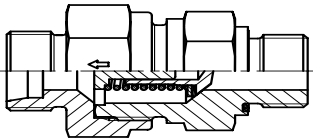
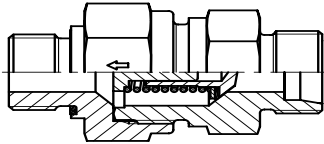
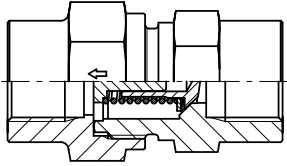
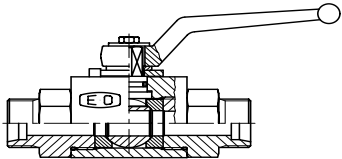
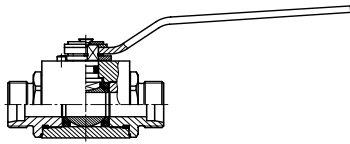
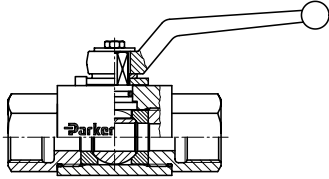
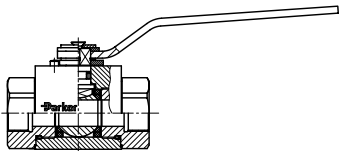
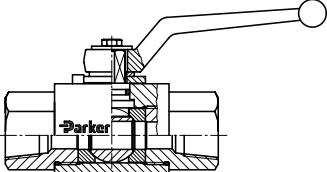
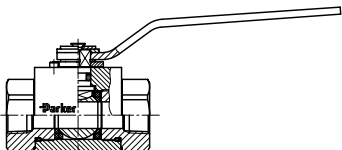

# 阀

## 单向阀

<p>RHD B-170</p>  <p>24°锥 / 24°锥 直通单向阀</p>	<p>RHV-R-ED B-171</p>  <p>24°锥 / BSPP 端直通单向阀</p>	<p>RHZ-R-ED B-172</p>  <p>BSPP / 24°锥 端直通单向阀</p>
<p>RHV-M-ED B-173</p>  <p>24°锥 / 公制螺纹 端直通单向阀</p>	<p>RHZ-M-ED B-174</p>  <p>公制螺纹 / 24°锥 端直通单向阀</p>	<p>RHDI B-175</p>  <p>BSPP 内螺纹 / BSPP 内螺纹 直通单向阀</p>

## 二通球阀

<p>KH(S) B-176</p>  <p>24°锥 / 24°锥 二通球阀 - 碳钢</p>	<p>KH(71) B-177</p>  <p>24°锥 / 24°锥 二通球阀 - 不锈钢</p>	<p>KH-BSPP(S) B-178</p>  <p>BSPP 内螺纹 / BSPP 内螺纹 二通球阀 - 碳钢</p>
<p>KH-BSPP(71) B-179</p>  <p>BSPP 内螺纹 / BSPP 内螺纹 二通球阀 - 不锈钢</p>	<p>KH-NPT(S) B-180</p>  <p>NPT 内螺纹 / NPT 内螺纹 二通球阀 - 碳钢</p>	<p>KH-NPT(71) B-181</p>  <p>NPT 内螺纹 / NPT 内螺纹 二通球阀 - 不锈钢</p>

软管, 接头及设备

A

硬管接头及设备

B

快换接头

C

其他产品

D

A 软管, 接头及设备

### 三通球阀

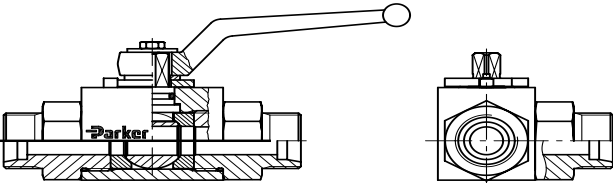
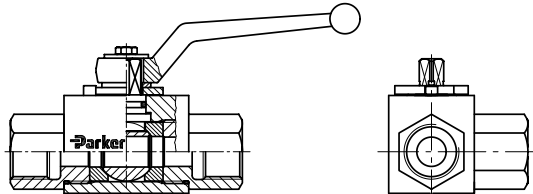
<p>KH 3/2(S) B-182</p>  <p>24°锥 / 24°锥 / 24°锥 三通球阀 - 碳钢</p>	<p>KH 3/2-BSPP(S) B-183</p>  <p>BSPP 内螺纹 / BSPP 内螺纹 / BSPP 内螺纹 三通球阀 - 碳钢</p>
--	--

B 硬管接头及设备

### 其他

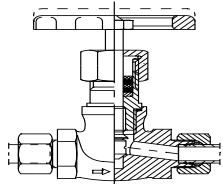
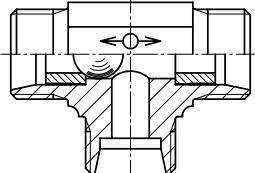
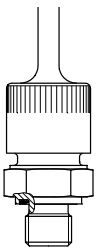
<p>VDHA B-184</p>  <p>24°锥 / 24°锥 高压截止阀</p>	<p>WV B-185</p>  <p>24°锥 / 24°锥 / 24°锥 梭阀</p>	<p>ELA B-186</p>  <p>排气阀</p>
---	---	--

C 快换接头

D 其他产品

## 技术信息

单向阀，管路梭阀及手动截止阀系列

### 单向阀压力可达 420 bar:

- 两端为管末端: RHD
- 外螺纹/管末端: RHV/RHZ
- 两端为内螺纹: RHDI
- 单向阀阀芯: RVP
- 单向阀阀芯: I-TL
- 测试压力下的泄漏量: 1 滴/分钟

### 管路梭阀:

- 压力可达 160 bar WV
- 测试压力下的泄漏量: 20 滴/分钟

### 高压截止阀:

- 压力可达 630 bar VDHA

### 手动球阀:

- 压力可达 500 bar KH
- 测试压力下的泄漏量: 0 滴/分钟

手动关断阀和球阀的压力设计系数为1.5（依照 DIN3230 T5及ISO5208）

### 注意!

请注意EO管端的许用压力

### 设计:

1. 关于材料，容许工作压力，温度，介质，外螺纹扭矩等信息，请查阅本样本相关内容。
2. 管末端连接应遵循派克EO/EO-2装配指导。
3. 进行管路连接时，阀体应被紧固。

### 碳钢

#### 材料:

阀体为碳钢，无六价铬镀锌或镀铜（镀层符合DIN 50938-FE//A/T4），阀芯钢球为碳钢镀硬铬，手柄为碳钢镀锌

#### 密封:

球座密封为POM（如：Delrin）手柄密封为NBR，例如：Perbunan）

#### 应用:

适用于石油基液压油，润滑油及燃料油。  
压力可达 500 bar

#### 温度范围:

-10 至 +100 °C

### 不锈钢

#### 材料:

阀体为不锈钢，阀芯球为不锈钢，手柄及连接体为不锈钢

#### 密封:

POM 球座(例如. Delrin), 手柄密封为NBR (例如: 丁苯橡胶 Perbunan), 功能螺母中的DOZ为 FKM (例如: FKM)

#### 应用:

适用于石油基液压油，润滑油及燃料油  
压力可达500 bar

#### 温度范围:

-30 至+100 °C

#### 注意:

为确定阀适用于特定场合，请告知我们准确的说明，包括使用的介质，额定工作压力（包括峰值压力），温度，以及阀的使用频率等。若用于水，请告知水或添加剂的种类。

## RHD/V/Z 单向阀

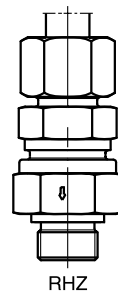
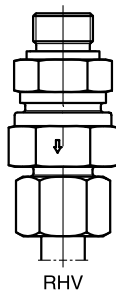
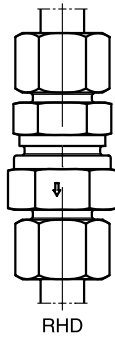
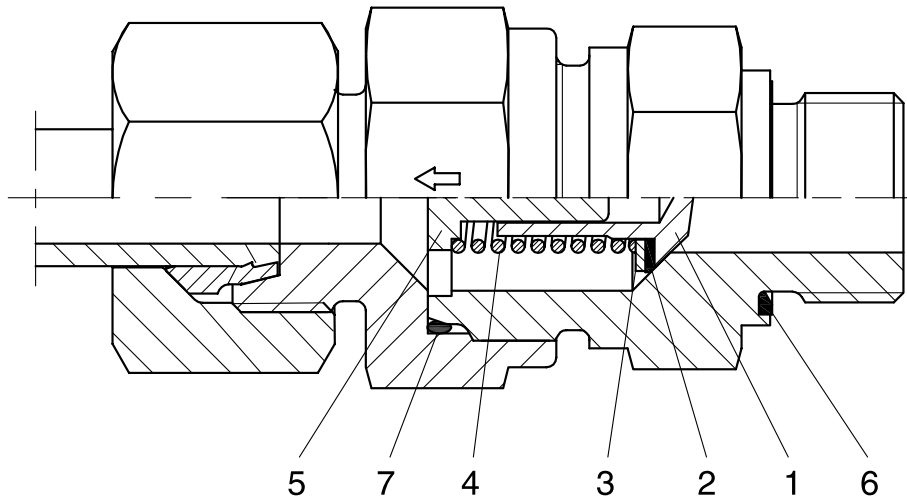

- 1: 锥阀芯
  - 2: 密封圈
  - 3: 挡圈
  - 4: 弹簧
  - 5: 导向杆
  - 6: ED密封圈
  - 7: O形圈
- DN = 公称尺寸 (mm)

### 特性:

单向阀带 90°锥形阀芯及弹性密封圈。通过对开启动作施加阻尼, 降低振动及噪声。无变径横截面。最大流速不超过 8 m/秒 (若需更高流速特殊测试用, 可另行要求)。RHV 和 RHZ 的外螺纹密封使用 ED 弹性密封。

### 开启压力:

标准为 1 bar (可提供 0.2, 0.5, 2, 3, 4, 5 及 6 bar; 请在订货时注明)。工作压力请查阅相应表格。开启压力偏差: ±20%。

### 材料:

- 碳钢镀锌 (CF 无六价铬), 密封材料为 NBR (例如: Perbunan), 可选 FKM (氟橡胶), 请咨询派克销售
- 不锈钢阀标配为 FKM 氟橡胶 (开启压力可达 3 bar)

### 安装:

参见 EO/EO 2 连接安装指导。  
单向阀均为防污染包装。

### 介质:

液压油, 低燃性液压流体。若用于压缩空气, 请在订单中说明。  
不适用于蒸汽, 易燃易爆气体, 或氧气。  
应用于水或其他介质, 请咨询派克公司。

软管, 接头及设备

A

硬管接头及设备

B

快换接头

C

其他产品

D

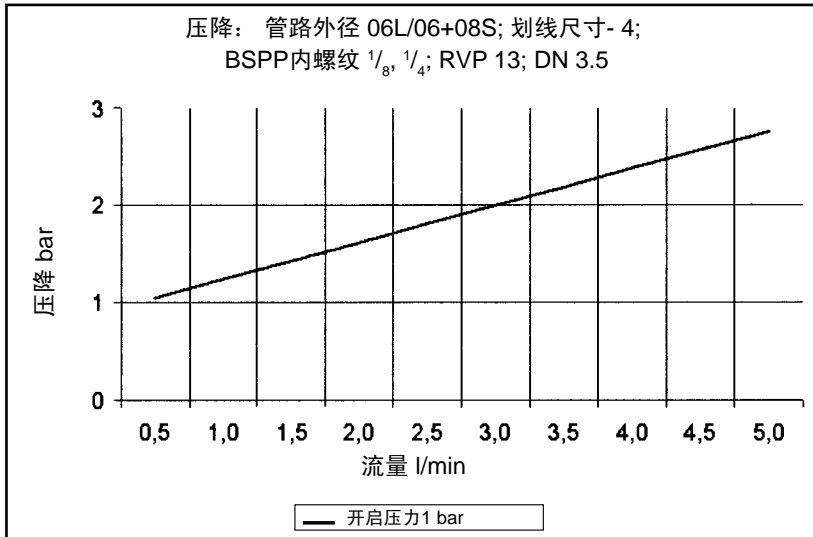

图表中所示均为最大流速为8米/秒时的流量峰值, 单位升/分

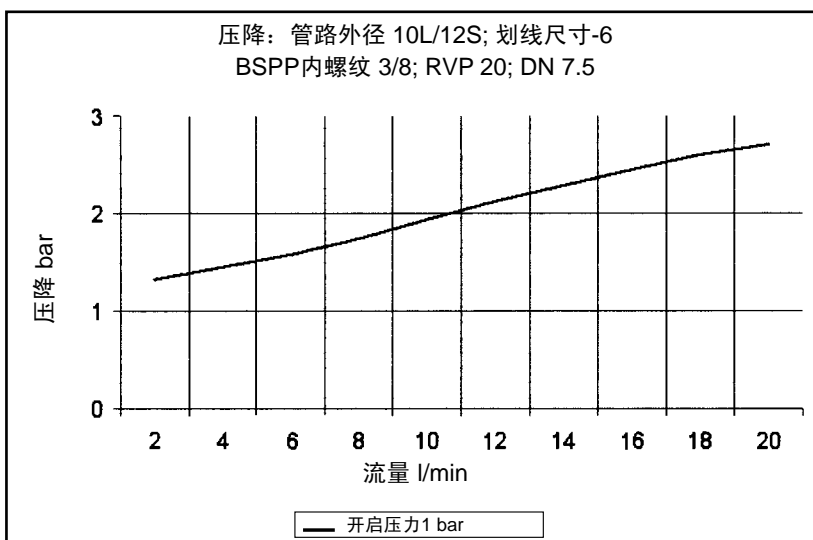
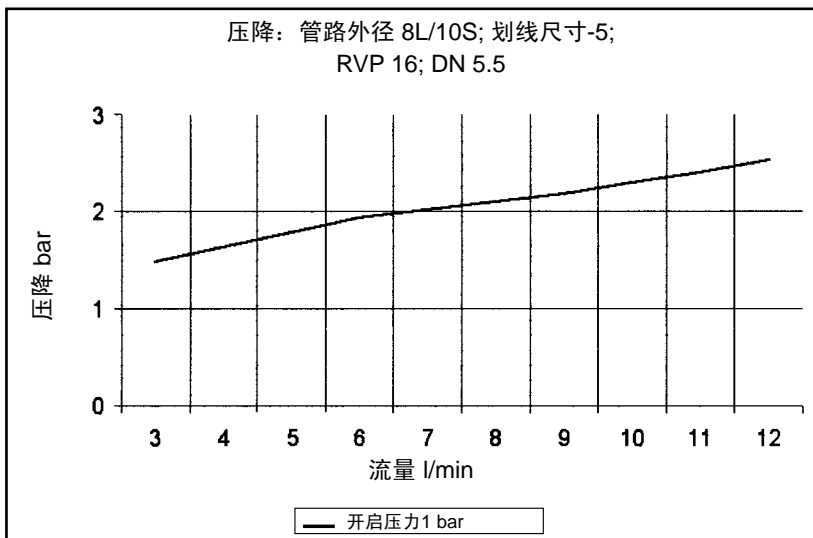

A 软管, 接头及设备

B 硬管接头及设备

C 快换接头

D 其他产品

A 软管, 接头及设备

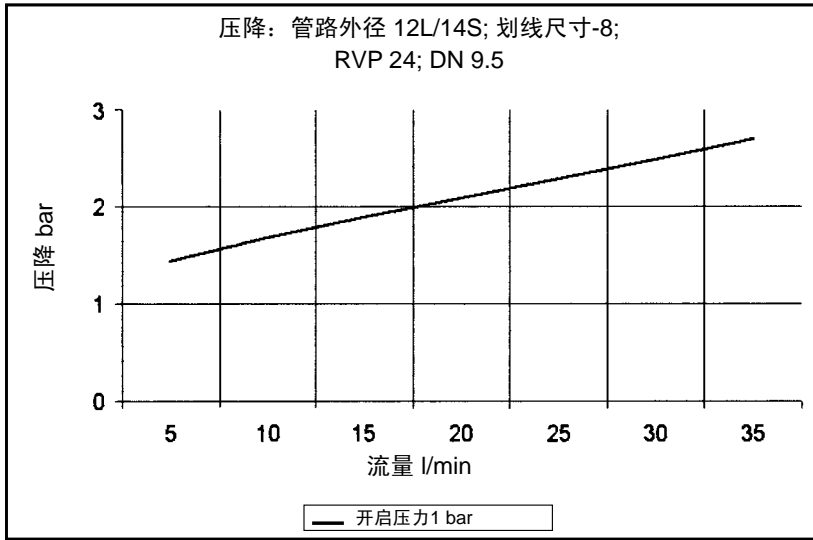

图表中所示均为最大流速为8米/秒时的流量峰值, 单位升/分

B 硬管接头及设备

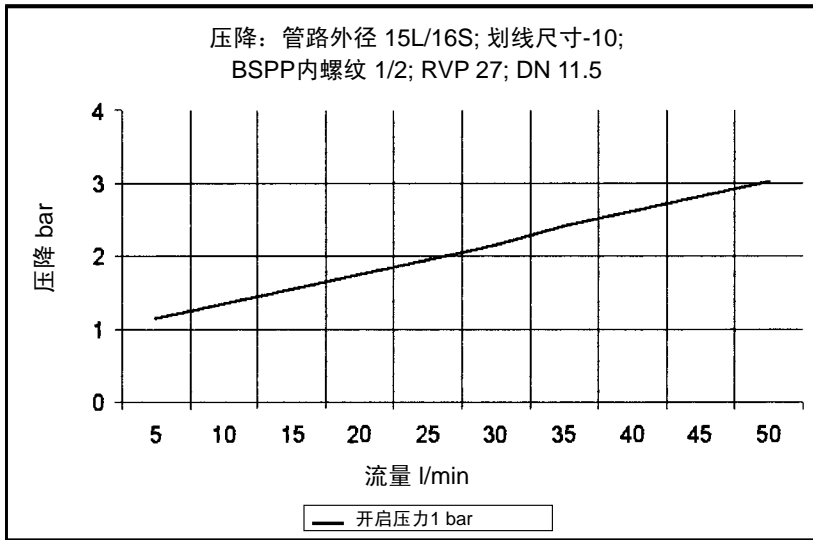

C 快换接头

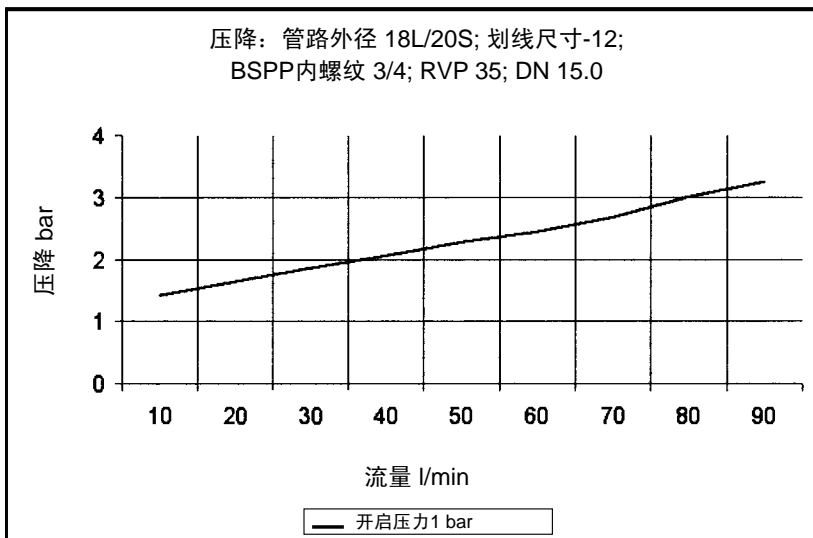

D 其他产品

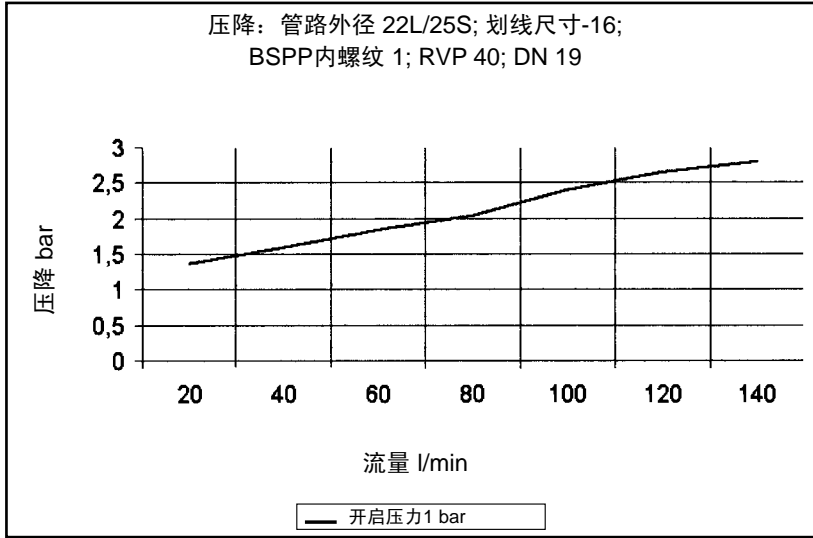

图表中所示均为最大流速为8米/秒时的流量峰值，单位升/分

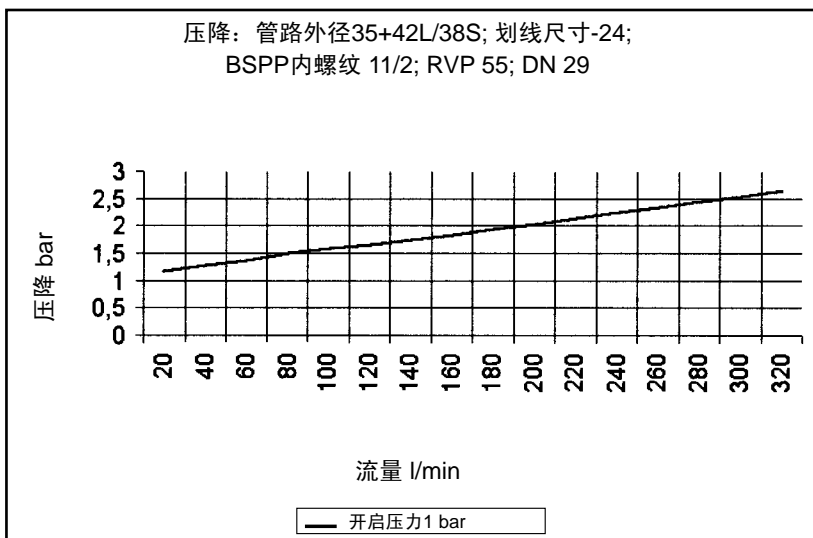
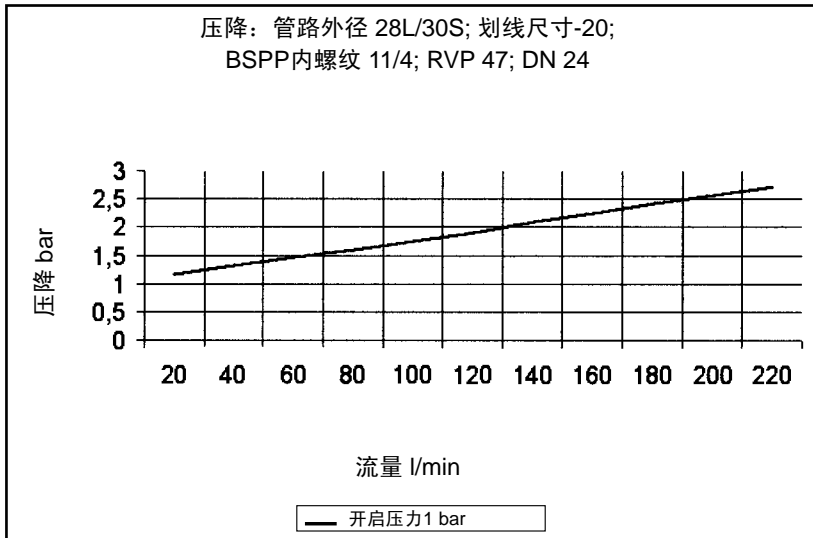

A 软管, 接头及设备

B 硬管接头及设备

C 快换接头

D 其他产品

# RHD 直通单向阀

EO 24°锥 / EO 24°锥

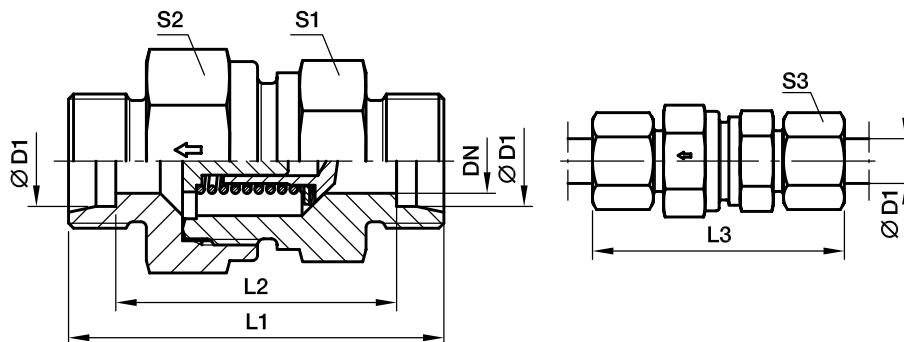

系列	钢管 外径 D1	CF DN	71		L2	L3	S1	CF		S3	重量 g/件	订货号	PN (bar)		
			DN	L1				S2	S2				CF	71	
L	06	3.5	3.5	43.0	43.0	29.0	58.0	17	17	17	14	46	RHD06LOMD	400	250
	08	5.5	5.5	44.0	44.9	30.0	59.0	19	19	19	17	61	RHD08LOMD	400	250
	10	7.5	7.5	55.0	54.5	40.5	69.5	22	24	24	19	104	RHD10LOMD	400	250
	12	9.5	9.5	58.0	57.5	43.5	72.5	27	30	30	22	166	RHD12LOMD	400	250
	15	11.0	11.5	62.0	61.5	47.5	77.5	27	32	32	27	192	RHD15LOMD	400	250
	18	14.0	14.0	67.0	66.5	51.5	83.5	36	41	36	32	292	RHD18LOMD	400	160
	22	18.0	18.0	77.0	76.5	61.5	93.5	41	46	46	36	472	RHD22LOMD	250	160
	28	23.0	23.0	85.0	84.5	69.5	102.5	50	55	55	41	746	RHD28LOMD	250	100
	35	29.0	29.0	96.0	95.5	74.5	117.5	60	65	60	50	1062	RHD35LOMD	250	100
42	29.0	29.0	96.0	96.0	74.0	119.0	65	70	70	60	1518	RHD42LOMD	250	100	
S	06	3.5	3.5	48.5	48.5	34.5	63.5	19	19	19	17	70	RHD06SOMD	420	400
	08	3.5	3.5	48.5	48.5	34.5	63.5	19	19	19	19	74	RHD08SOMD	420	400
	10	5.5	5.5	55.5	55.5	40.5	72.5	22	24	24	22	121	RHD10SOMD	420	400
	12	7.5	7.5	57.5	57.5	42.5	74.5	24	27	27	24	148	RHD12SOMD	420	400
	14	9.5	9.5	64.0	63.5	47.5	82.5	27	32	32	27	218	RHD14SOMD	420	315
	16	11.0	11.5	68.0	67.5	50.5	86.5	32	36	36	30	286	RHD16SOMD	420	315
	20	15.0	15.0	76.0	75.5	54.5	97.5	41	50	46	36	506	RHD20SOMD	420	250
	25	19.0	19.0	83.0	82.5	58.5	106.5	46	55	50	46	639	RHD25SOMD	420	250
	30	24.0	24.0	97.0	96.5	69.5	122.5	60	60	60	50	1157	RHD30SOMD	250	250
38	29.0	29.0	108.0	107.5	75.5	136.5	65	70	70	60	1650	RHD38SOMD	250	250	

订货示例:

碳钢, 无六价铬镀锌: RHD12LOMDCF

316Ti 不锈钢: RHD12LOMD71

注: 订货号不含螺母卡套

样本尺寸仅供参考, 请以实际产品尺寸为准。

A 软管, 接头及设备

B 硬管接头及设备

C 快换接头

D 其他产品



## RHV-R-ED 端直通单向阀

EO24°锥 / BSPP外螺纹 - ED密封 (ISO 1179)

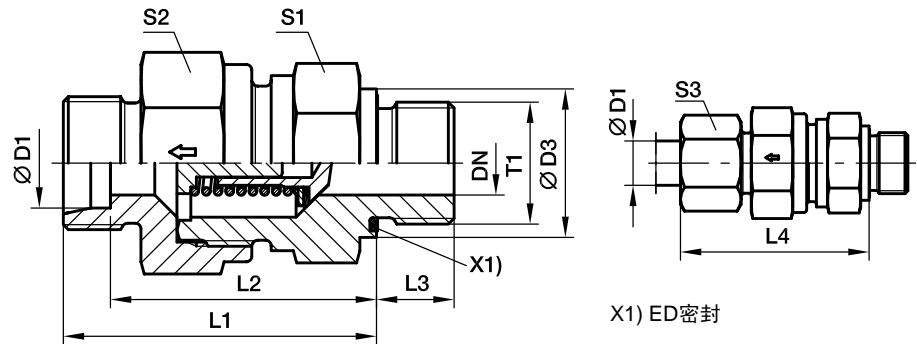

系列	钢管 外径	CF	71		CF	71		L2	L3	L4	S1	S2	S2	S3	重量 g/件	订货号	PN (bar)	
			DN	DN		L1	L1										CF	71
L	06	G 1/8 A	3.5	3.5	14	35.0	35.0	28.0	8	42.5	17	17	17	14	47	RHV06LREDDOMD	400	250
	08	G 1/4 A	5.5	5.5	19	37.0	37.0	30.0	12	44.5	19	19	19	17	62	RHV08LREDDOMD	400	250
	10	G 1/4 A	7.5	7.5	19	46.0	45.5	38.5	12	53.0	22	24	24	19	105	RHV10LREDDOMD	400	250
	12	G 3/8 A	9.5	9.5	22	50.0	49.5	42.5	12	57.0	27	30	30	22	175	RHV12LREDDOMD	400	250
	15	G 1/2 A	11.0	11.5	27	53.0	52.5	45.5	14	60.5	27	32	32	27	205	RHV15LREDDOMD	400	250
	18	G 1/2 A	14.0	14.0	27	58.0	57.5	50.0	14	66.0	36	41	36	32	294	RHV18LREDDOMD	400	160
	22	G 3/4 A	18.0	18.0	32	63.0	62.5	55.0	16	71.0	41	46	46	36	450	RHV22LREDDOMD	250	160
	28	G 1 A	23.0	23.0	40	71.0	70.5	63.0	18	79.5	50	55	55	41	720	RHV28LREDDOMD	250	100
	35	G 1 1/4 A	29.0	29.0	50	80.0	79.5	69.0	20	90.5	60	65	60	50	1050	RHV35LREDDOMD	250	100
42	G 1 1/2 A	29.0	29.0	55	80.0	79.5	68.5	22	91.0	65	70	70	60	1560	RHV42LREDDOMD	250	100	
S	06	G 1/4 A	3.5	3.5	19	38.5	38.5	31.5	12	46.0	19	19	19	17	73	RHV06SREDDOMD	420	400
	08	G 1/4 A	3.5	3.5	19	38.5	38.5	31.5	12	46.0	19	19	19	19	79	RHV08SREDDOMD	420	400
	10	G 3/8 A	5.5	5.5	22	45.5	45.5	38.0	12	54.0	22	24	24	22	132	RHV10SREDDOMD	420	400
	12	G 3/8 A	7.5	7.5	22	48.5	48.5	41.0	12	57.0	24	27	27	24	153	RHV12SREDDOMD	420	400
	14	G 1/2 A	9.5	9.5	27	53.0	52.5	44.5	14	62.0	27	32	32	27	230	RHV14SREDDOMD	420	315
	16	G 1/2 A	11.0	11.5	27	57.0	56.5	48.0	14	66.0	32	36	36	30	293	RHV16SREDDOMD	420	315
	20	G 3/4 A	15.0	15.0	32	63.0	62.5	52.0	16	73.5	41	50	46	36	511	RHV20SREDDOMD	420	250
	25	G 1 A	19.0	19.0	40	67.0	66.5	54.5	18	78.5	46	55	50	46	648	RHV25SREDDOMD	420	250
	30	G 1 1/4 A	24.0	24.0	50	78.0	77.5	64.0	20	90.5	60	60	60	50	1176	RHV30SREDDOMD	250	250
38	G 1 1/2 A	29.0	29.0	55	86.0	85.5	69.5	22	100.0	65	70	70	60	1624	RHV38SREDDOMD	250	250	

订货示例:

碳钢, 无六价铬镀锌: RHV12LREDDOMDCF

316Ti 不锈钢: RHV12LREDDOMD71

注: 订货号不含螺母卡套

样本尺寸仅供参考, 请以实际产品尺寸为准。

**RHZ-R-ED 端直通单向阀**  
BSPP外螺纹 – ED密封 (ISO 1179) / EO 24°锥

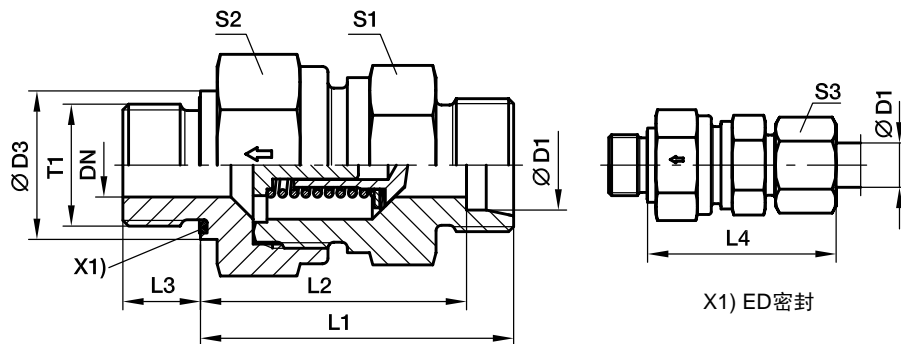

系列	钢管 外径	CF	71		CF	71		CF	71		CF	71		重量 g/件	订货号	PN (bar)		
			D1	T1		DN	DN		D3	L1		L1	L2			L3	L4	S1
L	06	G 1/8 A	3.5	3.5	14	33.5	-	26.5	8	41.0	17	17	17	14	44	RHZ06LREDDOMD	400	250
	08	G 1/4 A	5.5	5.5	19	35.5	-	28.5	12	43.0	19	19	19	17	59	RHZ08LREDDOMD	400	250
	10	G 1/4 A	7.5	7.5	19	46.0	-	38.5	12	53.0	22	24	24	19	125	RHZ10LREDDOMD	400	250
	12	G 3/8 A	9.5	9.5	22	48.0	-	40.5	12	55.0	27	30	30	22	161	RHZ12LREDDOMD	400	250
	15	G 1/2 A	11.0	11.5	27	50.0	-	42.5	14	57.5	27	32	32	27	186	RHZ15LREDDOMD	400	250
	18	G 1/2 A	14.0	14.0	27	56.0	-	48.0	14	64.0	36	41	36	32	275	RHZ18LREDDOMD	400	160
	22	G 3/4 A	18.0	18.0	32	64.0	-	56.0	16	72.0	41	46	46	36	463	RHZ22LREDDOMD	250	160
	28	G 1 A	23.0	23.0	40	72.0	-	64.0	18	80.5	50	55	55	41	721	RHZ28LREDDOMD	250	100
	35	G 1 1/4 A	29.0	29.0	50	81.0	-	70.0	20	91.5	60	65	60	50	1073	RHZ35LREDDOMD	250	100
	42	G 1 1/2 A	29.0	29.0	55	82.0	-	70.5	22	93.0	65	70	70	60	1602	RHZ42LREDDOMD	250	100
S	06	G 1/4 A	3.5	3.5	19	38.5	-	31.5	12	46.0	19	19	19	17	71	RHZ06SREDDOMD	420	400
	08	G 1/4 A	3.5	3.5	19	38.5	-	31.5	12	46.0	19	19	19	19	74	RHZ08SREDDOMD	420	400
	10	G 3/8 A	5.5	5.5	22	45.5	-	38.0	12	54.0	22	24	24	22	128	RHZ10SREDDOMD	420	400
	12	G 3/8 A	7.5	7.5	22	48.5	-	41.0	12	57.0	24	27	27	24	152	RHZ12SREDDOMD	420	400
	14	G 1/2 A	9.5	9.5	27	52.0	-	43.5	14	61.0	27	32	32	27	223	RHZ14SREDDOMD	420	315
	16	G 1/2 A	11.0	11.5	27	55.0	-	46.0	14	64.0	32	36	36	30	275	RHZ16SREDDOMD	420	315
	20	G 3/4 A	15.0	15.0	32	61.0	-	50.0	16	71.5	41	50	46	36	490	RHZ20SREDDOMD	420	250
	25	G 1 A	19.0	19.0	40	67.0	-	54.5	18	78.5	50	55	50	46	647	RHZ25SREDDOMD	420	250
	30	G 1 1/4 A	24.0	24.0	50	78.0	-	64.0	20	90.5	55	60	60	50	1180	RHZ30SREDDOMD	250	250
	38	G 1 1/2 A	29.0	29.0	55	88.0	-	71.5	22	102.0	65	70	70	60	1670	RHZ38SREDDOMD	250	250

订货示例:

碳钢, 无六价铬镀锌: RHZ12LREDDOMDCF

316Ti 不锈钢: RHZ12LREDDOMD71

注: 订货号不含螺母卡套

样本尺寸仅供参考, 请以实际产品尺寸为准。

A 软管, 接头及设备

B 硬管接头及设备

C 快换接头

D 其他产品

**RHV-M-ED 端直通单向阀**  
EO 24°锥 / 公制外螺纹- ED密封 (ISO 9974)

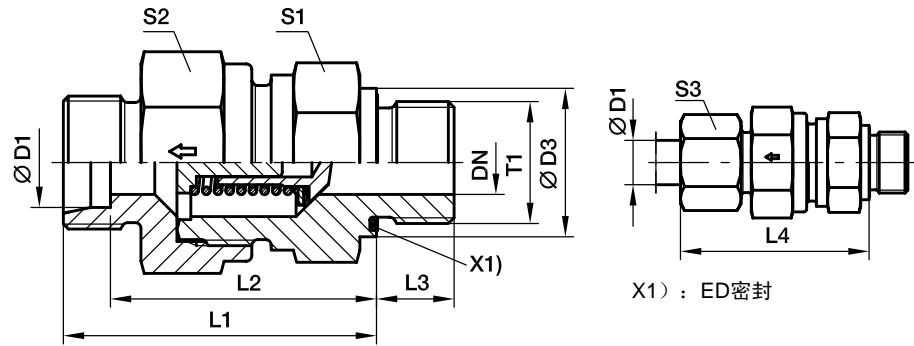

X1) : ED密封

系列	钢管 外径	CF	71	CF	71	CF	71	CF	71	CF	71	CF	71	重量 g/件	订货号	PN (bar)		
																D1	T1	DN
L	06	M 10×1.0	3.5	3.5	14	35.0	-	28.0	8	42.5	17	17	17	14	46	RHV06LMEDOMD	400	250
	08	M 12×1.5	5.5	5.5	17	36.0	-	29.0	12	43.5	19	19	19	17	58	RHV08LMEDOMD	400	250
	10	M 14×1.5	7.5	7.5	19	45.5	-	38.5	12	53.0	22	24	34	19	108	RHV10LMEDOMD	400	250
	12	M 16×1.5	9.5	9.5	22	49.5	-	42.5	12	57.0	27	30	30	22	173	RHV12LMEDOMD	400	250
	15	M 18×1.5	11.0	11.5	24	52.5	-	45.5	12	60.5	27	32	32	27	192	RHV15LMEDOMD	400	250
	18	M 22×1.5	14.0	14.0	27	56.0	-	50.0	14	66.0	36	41	36	32	298	RHV18LMEDOMD	400	160
	22	M 26×1.5	18.0	18.0	32	64.0	-	55.0	16	71.0	41	46	46	36	446	RHV22LMEDOMD	250	160
	28	M 33×2.0	23.0	23.0	40	72.0	-	63.0	18	79.5	50	55	55	41	722	RHV28LMEDOMD	250	100
	35	M 42×2.0	29.0	29.0	50	81.0	-	69.0	20	90.5	60	65	60	50	1053	RHV35LMEDOMD	250	100
42	M 48×2.0	29.0	29.0	55	82.0	-	68.5	22	91.0	65	70	70	60	1563	RHV42LMEDOMD	250	100	
S	06	M 12×1.5	3.5	3.5	17	38.5	-	31.5	12	46.0	19	19	19	17	70	RHV06SMEDOMD	420	400
	08	M 14×1.5	3.5	3.5	19	38.5	-	31.5	12	46.0	19	19	19	19	76	RHV08SMEDOMD	420	400
	10	M 16×1.5	5.5	5.5	22	45.5	-	38.0	12	54.0	22	24	24	22	124	RHV10SMEDOMD	420	400
	12	M 18×1.5	7.5	7.5	24	48.5	-	41.0	12	57.0	24	27	27	24	157	RHV12SMEDOMD	420	400
	14	M 20×1.5	9.5	9.5	26	52.5	-	44.5	14	62.0	27	32	32	27	215	RHV14SMEDOMD	420	315
	16	M 22×1.5	11.0	11.5	27	55.0	-	48.0	14	66.0	32	36	36	30	296	RHV16SMEDOMD	420	315
	20	M 27×2.0	15.0	15.0	32	61.0	-	52.0	16	73.5	41	50	46	36	521	RHV20SMEDOMD	420	250
	25	M 33×2.0	19.0	19.0	40	67.0	-	54.5	18	78.5	46	55	50	46	648	RHV25SMEDOMD	420	250
	30	M 42×2.0	24.0	24.0	50	78.0	-	64.0	20	90.5	60	60	60	50	1178	RHV30SMEDOMD	250	250
	38	M 48×2.0	29.0	29.0	55	88.0	-	69.5	22	100.0	65	70	70	60	1627	RHV38SMEDOMD	250	250

订货示例:

碳钢, 无六价铬镀锌: RHV12LMEDOMDCF

316Ti 不锈钢: RHV12LMEDOMD71

注: 订货号不含螺母卡套

样本尺寸仅供参考, 请以实际产品尺寸为准。

## RHZ-M-ED 端直通单向阀

公制外螺纹 – ED密封 (ISO 9974) / EO24°锥

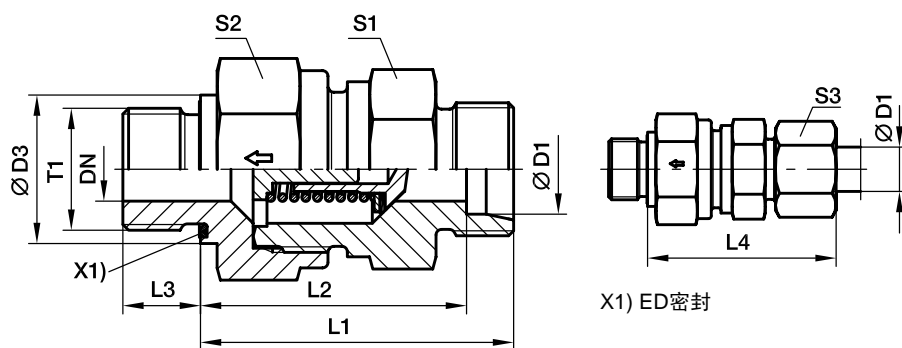

系列	钢管 外径 D1	T1	DN	D3	L1	L2	L3	L4	S1	S2	S3	重量 g/件	订货号	PN (bar)	
														CF	71
L	06	M 10x1.0	3.5	14	33.5	26.5	8	41.0	17	17	14	44	RHZ06LMEDOMD	400	250
	08	M 12x1.5	5.5	17	35.5	28.5	12	43.0	19	19	17	58	RHZ08LMEDOMD	400	250
	10	M 14x1.5	7.5	19	45.5	38.5	12	53.0	22	24	19	104	RHZ10LMEDOMD	400	250
	12	M 16x1.5	9.5	22	47.5	40.5	12	55.0	27	30	22	169	RHZ12LMEDOMD	400	250
	15	M 18x1.5	11.5	24	49.5	42.5	12	57.5	27	32	27	174	RHZ15LMEDOMD	400	250
	18	M 22x1.5	14.0	27	55.5	48.0	14	64.0	36	41	32	279	RHZ18LMEDOMD	400	160
	22	M 26x1.5	18.0	32	63.5	56.0	16	72.0	41	46	36	459	RHZ22LMEDOMD	250	160
	28	M 33x2.0	23.0	40	71.5	64.0	18	80.5	50	55	41	721	RHZ28LMEDOMD	250	100
	35	M 42x2.0	29.0	50	80.5	70.0	20	91.5	60	65	50	1078	RHZ35LMEDOMD	250	100
42	M 48x2.0	29.0	55	81.5	70.5	22	93.0	65	70	60	1601	RHZ42LMEDOMD	250	100	
S	06	M 12x1.5	3.5	17	38.5	31.5	12	46.0	19	19	17	70	RHZ06SMEDOMD	420	400
	08	M 14x1.5	3.5	19	38.5	31.5	12	46.0	19	19	19	75	RHZ08SMEDOMD	420	400
	10	M 16x1.5	5.5	22	45.5	38.0	12	54.0	22	24	22	123	RHZ10SMEDOMD	420	400
	12	M 18x1.5	7.5	24	48.5	41.0	12	57.0	24	27	24	157	RHZ12SMEDOMD	420	400
	14	M 20x1.5	9.5	26	51.5	43.5	14	61.0	27	32	27	214	RHZ14SMEDOMD	420	315
	16	M 22x1.5	11.5	27	54.5	46.0	14	64.0	32	36	30	279	RHZ16SMEDOMD	420	315
	20	M 27x2.0	15.0	32	60.5	50.0	16	71.5	41	50	36	487	RHZ20SMEDOMD	420	250
	25	M 33x2.0	19.0	40	68.0	54.5	18	78.5	46	55	46	647	RHZ25SMEDOMD	420	250
	30	M 42x2.0	24.0	50	77.5	64.0	20	90.5	60	60	50	1180	RHZ30SMEDOMD	250	250
38	M 48x2.0	29.0	55	87.5	71.5	22	102.0	65	70	60	1669	RHZ38SMEDOMD	250	250	

订货示例:

碳钢, 无六价铬镀锌: RHZ12LMEDOMDCF

316Ti 不锈钢: RHZ12LMEDOMD71

注: 订货号不含螺母卡套

样本尺寸仅供参考, 请以实际产品尺寸为准。

## RHD1 内螺纹直通单向阀

BSPP内螺纹(ISO 1179-1 / BSPP内螺纹(ISO 1179-1)

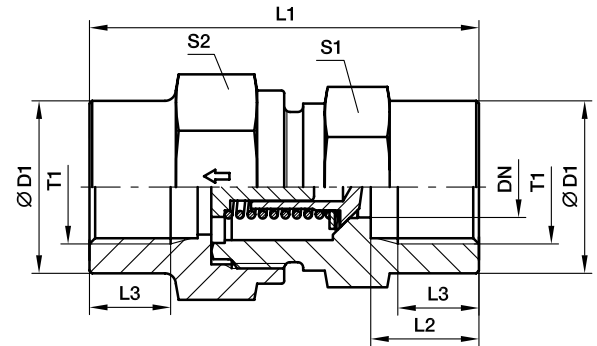

系列	T1	DN	D1	L1	L2	L3	S1	S2	重量 g/件	订货号	PN (bar)	
											CF	71
L	G 1/8	3.5	19	42.5	12.0	8.0	19	19	76	RHD11/8	400	400
	G 1/4	3.5	19	51.0	16.0	12.0	19	19	82	RHD11/4	400	400
	G 3/8	7.5	24	60.0	17.0	12.0	24	27	157	RHD13/8	400	400
	G 1/2	11.5	32	72.0	20.0	15.0	32	36	344	RHD11/2	315	315
	G 3/4	15.0	41	84.0	22.0	16.5	41	46	664	RHD13/4	250	250
	G 1	19.0	46	95.0	25.5	19.0	46	50	821	RHD11	250	250
	G 1 1/4	24.0	60	110.0	28.0	21.5	60	60	1581	RHD111/4	250	250
	G 1 1/2	29.0	65	114.0	28.5	22.0	65	70	1919	RHD111/2	250	250

订货示例:

碳钢, 无六价铬镀锌: RHD13/8CF

316Ti 不锈钢: RHD13/871

注: 订货号不含螺母卡套

A 软管, 接头及设备

B 硬管接头及设备

C 快换接头

D 其他产品

样本尺寸仅供参考, 请以实际产品尺寸为准。

# KH 2位2通碳钢球阀

EO24°锥 / EO24°锥

A 软管, 接头及设备

B 硬管接头及设备

C 快换接头

D 其他产品

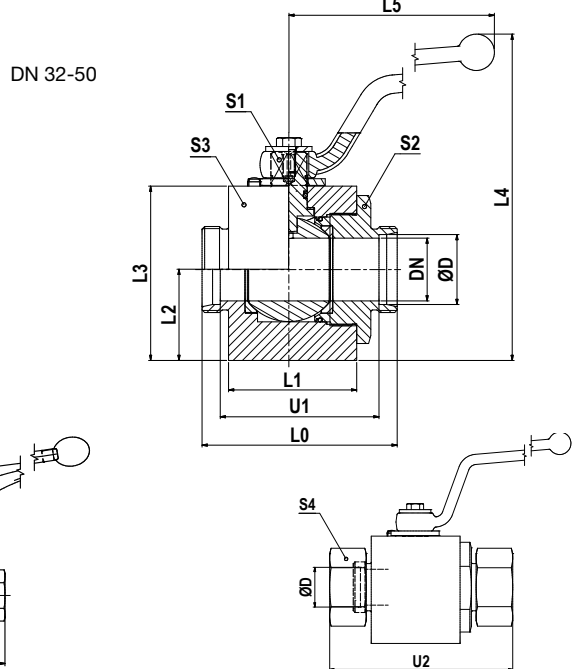
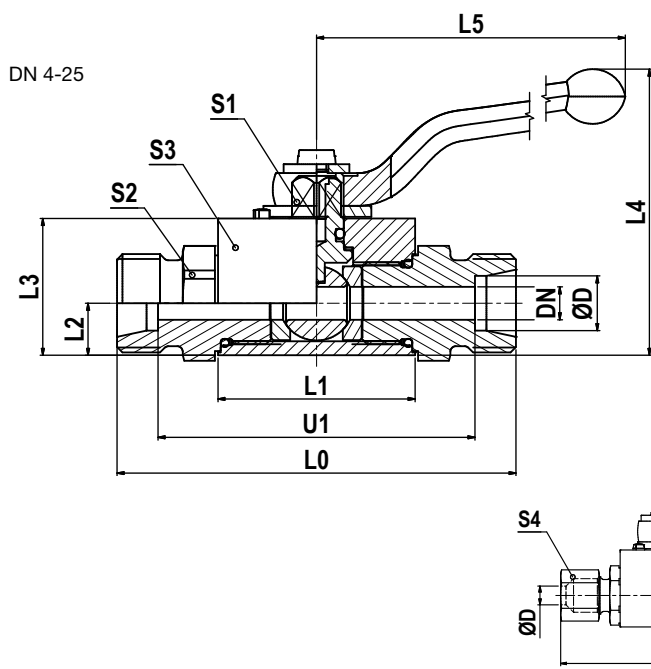

系列	钢管 外径 D1	DN	L0	L1	L2	L3	L4	L5	U1	U2	S1	S2	S3	S4	重量 g/件	订货号	PN (bar)
L <sup>1)</sup>	06	4	67	36.0	9.5	25	54.5	76	53	82	7	19	20	14	195	KH06LCFX	500
	08	6	67	36.0	9.5	25	54.5	76	53	82	7	19	20	17	190	KH08LCFX	500
	10	8	75	45.0	14.5	35	67.5	100	61	90	8	24	30	19	420	KH10LCFX	500
	12	10	75	45.0	14.5	35	67.5	100	61	90	8	24	30	22	410	KH12LCFX	500
	15	13	83	51.0	17.0	40	93.0	113	69	99	10	30	35	27	631	KH15LCFX	500
	18	16	82	50.0	20.0	45	98.0	113	67	99	10	36	45	32	850	KH18LCFX	420
	22	20	99	60.0	24.0	55	120.0	171	84	116	14	41	45	36	1210	KH22LCFX	420
	28	25	108	70.0	26.0	60	125.0	171	93	126	14	50	55	41	1750	KH28LCFX	420
	35	32/25	116	70.0	26.0	60	125.0	171	95	138	14	50	55	50	1820	KH35LDN25CFX	420
	35	32	121	79.0	49.5	95	188.0	228	100	143	17	60	Ø99	50	4888	KH35LCFX	420
	42	40/25	121	70.0	26.0	60	125.0	171	99	144	14	55	55	60	1940	KH42LDN25CFX	420
	42	40	118	77.5	54.5	105	198.0	228	96	141	17	75	Ø109	60	5590	KH42LCFX	420
	S <sup>2)</sup>	08	5	73	36.0	9.5	25	54.5	76	59	88	7	19	20	19	214	KH08SCFX
10		6	73	36.0	9.5	25	54.5	76	58	90	7	19	20	22	220	KH10SCFX	500
12		8	77	45.0	14.5	35	67.5	100	62	94	8	24	30	24	430	KH12SCFX	500
14		10	81	45.0	14.5	35	67.5	100	65	100	8	24	30	27	440	KH14SCFX	500
16		13	87	51.0	17.0	40	93.0	113	70	106	10	30	35	30	649	KH16SCFX	500
20		16	90	50.0	20.0	45	98.0	113	69	112	10	36	45	36	900	KH20SCFX	420
25		20	107	60.0	24.0	55	120.0	171	83	131	14	41	45	46	1290	KH25SCFX	420
30		25	120	70.0	26.0	60	125.0	171	93	146	14	50	55	50	1880	KH30SCFX	420
38		32/25	134	70.0	26.0	60	125.0	171	102	163	14	55	55	60	1950	KH38SDN25CFX	420
38		32	127	73.0	49.5	95	188.0	228	95	156	17	60	Ø99	60	4740	KH38SCFX	420

订货示例:

碳钢, 无六价铬镀锌: KH06LCFX

注: 订货号不含螺母卡套

订货号后缀			
材质	表面处理	示例	标准密封
碳钢, 无六价铬镀锌	CF	KH06LCFX	POM / NBR

样本尺寸仅供参考, 请以实际产品尺寸为准。

# KH 2位2通不锈钢球阀

EO24°锥 / EO24°锥

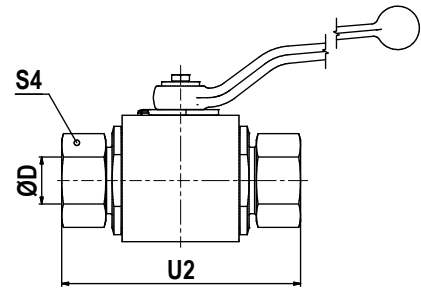
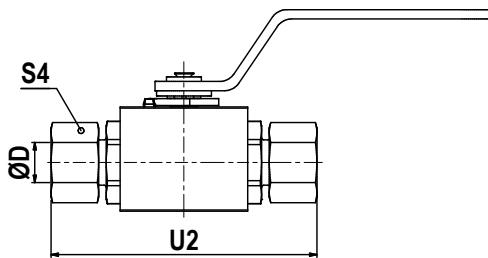
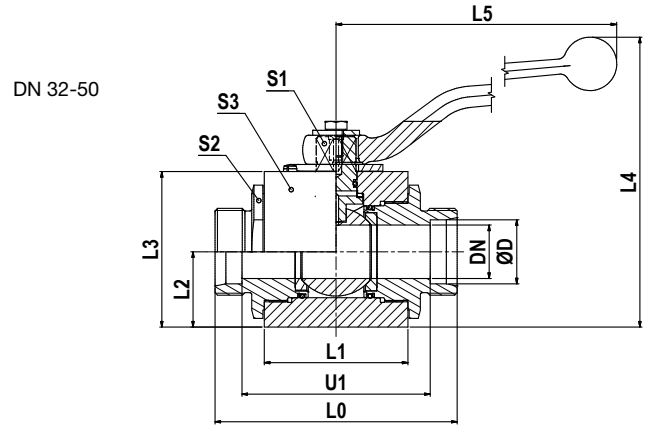
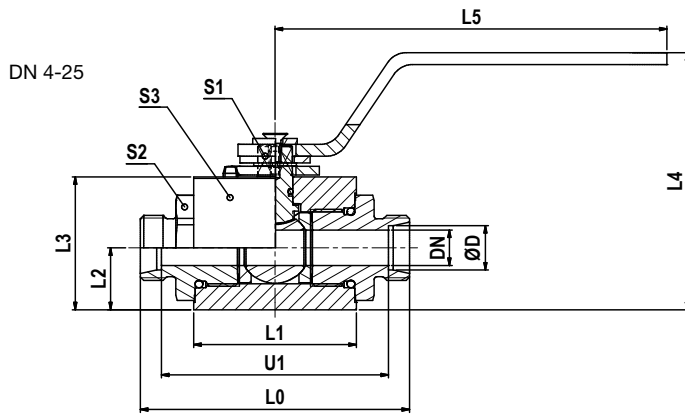

系列	钢管 外径 D1	DN	L0	L1	L2	L3	L4	L5	U1	U2	S1	S2	S3	S4	重量 g/件	订货号	PN (bar)
L <sup>1)</sup>	06	4	73	41.5	13.5	30.0	54	80.0	58.5	88	7	22	30	14	391	KH06L71X	500
	08	6	73	41.5	13.5	30.0	54	80.0	58.5	88	7	22	30	17	392	KH08L71X	500
	10	8	87	53.0	18.0	40.0	82	132.5	73.0	102	8	30	40	19	833	KH10L71X	500
	12	10	87	53.0	18.0	40.0	82	132.5	73.0	102	8	30	40	22	812	KH12L71X	500
	15	12	91	55.0	21.0	45.0	87	132.5	76.5	107	10	32	45	27	1018	KH15L71X	500
	18	12	91	55.0	21.0	45.0	87	132.5	75.5	108	10	32	45	32	1059	KH18L71X	500
	22	20	105	65.0	31.0	65.0	118	190.0	89.5	122	14	46	65	36	2427	KH22L71X	400
	28	25	112	71.0	38.0	75.0	128	190.0	96.5	130	14	50	75	41	3313	KH28L71X	400
	35	32	145	86.0	45.0	93.0	174	320.0	123.5	167	19	70	Ø100	50	6230	KH35L71X	400
	42	40	150	92.0	52.0	104.5	185	320.0	127.5	173	19	80	Ø110	60	7706	KH42L71X	400
S <sup>2)</sup>	08	4	76	41.5	13.5	30.0	54	80.0	61.5	91	7	22	30	19	390	KH08S71X	500
	10	6	76	41.5	13.5	30.0	54	80.0	60.5	91	7	22	30	22	406	KH10S71X	500
	12	8	89	53.0	18.0	40.0	82	132.5	74.0	106	8	30	40	24	855	KH12S71X	500
	14	10	93	53.0	18.0	40.0	82	132.5	77.0	112	8	30	40	27	850	KH14S71X	500
	16	12	96	55.0	21.0	45.0	87	132.5	78.5	115	10	32	45	30	1050	KH16S71X	500
	20	12	99	55.0	21.0	45.0	87	132.5	77.5	121	10	32	45	36	1090	KH20S71X	500
	25	20	113	65.0	31.0	65.0	118	190.0	88.5	137	14	46	65	46	2490	KH25S71X	400
	30	25	124	71.0	38.0	75.0	128	190.0	96.5	150	14	50	75	50	3430	KH30S71X	400
	38	32	145	86.0	45.0	93.0	174	320.0	112.5	174	19	70	Ø100	60	5881	KH38S71X	400

订货示例:

316Ti 不锈钢: KH06L71X

注: 订货号不含螺母卡套

订货号后缀			
材质	表面处理	示例	标准密封
不锈钢	71	KH06L71X	POM / NBR

样本尺寸仅供参考, 请以实际产品尺寸为准。

# KH 2位2通BSPP 碳钢球阀

BSPP内螺纹 (ISO 1179-1) / BSPP内螺纹 (ISO 1179-1)

A 软管, 接头及设备

B 硬管接头及设备

C 快换接头

D 其他产品

DN 4-25

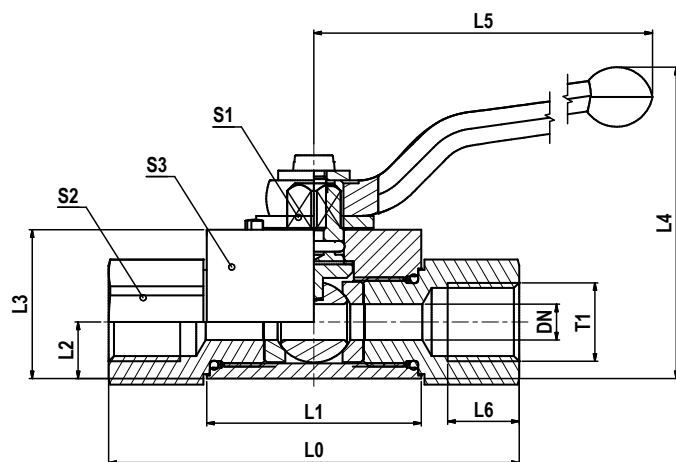

DN 32-50

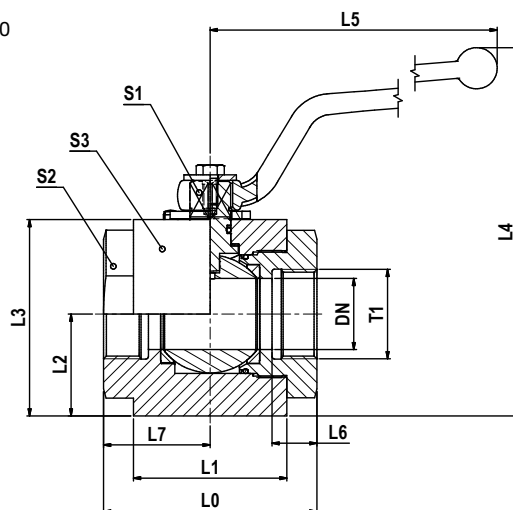

T1	DN	L0	L1	L2	L3	L4	L5	L6	L7	S1	S2	S3	重量 g/件	订货号	PN (bar)
G 1/8	5	69	36	9.5	25	54.5	76	12	-	7	19	20	220	KH1/8CFX	500
G 1/4	6	69	36	9.5	25	54.5	76	12	-	7	19	20	210	KH1/4CFX	500
G 3/8	10	73	45	14.5	35	67.5	100	14	-	8	24	30	430	KH3/8CFX	500
G 1/2	13	82	51	17.0	40	93.0	113	15	-	10	30	35	670	KH1/2CFX	500
G 5/8	16	88	50	20.0	45	98.0	113	18	-	10	36	45	973	KH5/8CFX	420
G 3/4	20	93	60	24.0	55	120.0	171	18	-	14	41	45	1280	KH3/4CFX	420
G 1	25	115	70	26.0	60	125.0	171	20	-	14	50	55	1982	KH1CFX	420
G 1 1/4	32	110	80	49.5	95	188.0	228	22	55	17	60	Ø99	4888	KH11/4CFX	420
G 1 1/4	32/25	134	70	26.0	60	125.0	171	22	-	14	50	55	2066	KH11/4DN25CFX	420
G 1 1/2	40	114	82	54.5	105	198.0	228	24	57	17	75	Ø109	6330	KH11/2CFX	420
G 1 1/2	40/25	139	70	26.0	60	125.0	171	24	-	14	55	55	2200	KH11/2DN25CFX	420
G 2	50	133	100	62.0	120	212.0	306	26	65	17	85	Ø124	9220	KH2CFX	420

订货示例:

碳钢, 无六价铬镀锌: KH1/8CFX

注: 订货号不含螺母卡套

订货号后缀			
材质	表面处理	示例	标准密封
碳钢, 无六价铬镀锌	CF	KH1/8CFX	POM / NBR

样本尺寸仅供参考, 请以实际产品尺寸为准。



# KH 2位2通BSP内螺纹球阀

BSP内螺纹 (ISO 1179-1) / BSP内螺纹 (ISO 1179-1)

DN 4-25

DN 32-50

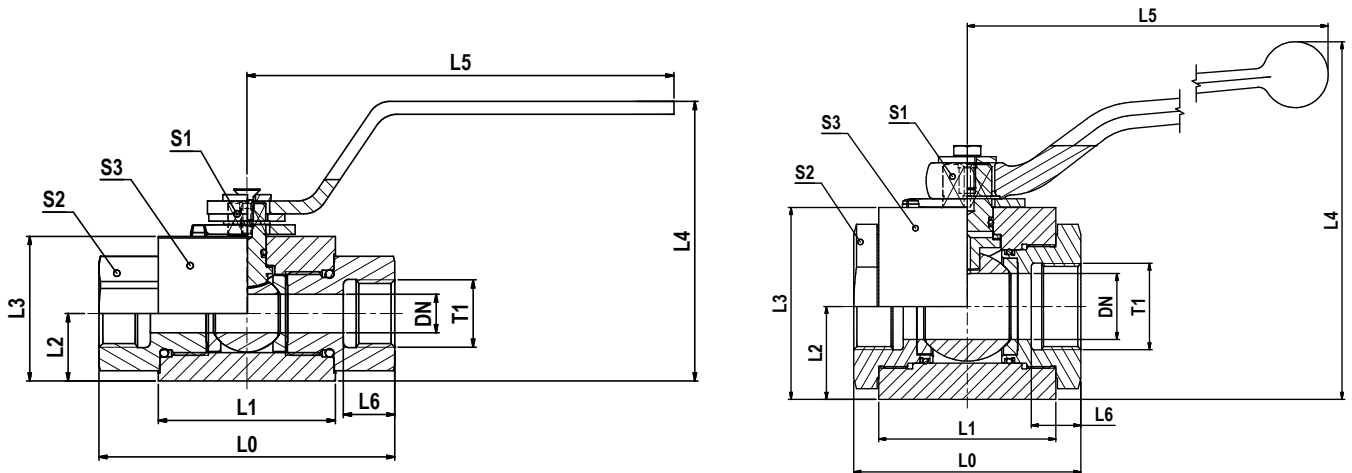

T1	DN	L0	L1	L2	L3	L4	L5	L6	S1	S2	S3	重量 g/件	订货号	PN (bar)
G 1/8	4	69	41.5	13.5	30.0	54	80.0	11.0	7	22	30	420	KH1/871X	500
G 1/4	6	75	41.5	13.5	30.0	54	80.0	14.0	7	22	30	427	KH1/471X	500
G 3/8	10	86	53.0	18.0	40.0	82	132.5	14.0	8	30	40	902	KH3/871X	500
G 1/2	12	92	55.0	21.0	45.0	87	132.5	16.0	10	32	45	1100	KH1/271X	500
G 3/4	20	111	65.0	31.0	65.0	118	190.0	18.0	14	46	65	2699	KH3/471X	400
G 1	25	122	71.0	38.0	75.0	128	190.0	20.0	14	50	75	3620	KH171X	400
G 1 1/4	32	110	86.0	45.0	93.0	174	320.0	24.0	19	70	Ø100	5688	KH11/471X	400
G 1 1/2	40	120	92.0	52.0	104.5	185	320.0	26.0	19	80	Ø110	7379	KH11/271X	400
G 2	50	140	97.0	59.5	119.5	201	320.0	27.5	19	95	Ø125	10086	KH271X	400

订货示例:

316Ti 不锈钢: KH1/871X

注: 订货号不含螺母卡套

订货号后缀			
材质	表面处理	示例	标准密封
不锈钢	71	KH1/871X	POM / NBR

样本尺寸仅供参考, 请以实际产品尺寸为准。

软管, 接头及设备

A

硬管接头及设备

B

快换接头

C

其他产品

D

## KH 2位2通NPT 碳钢球阀

NPT内螺纹 (SAE 476) / NPT 内螺纹 (SAE 476)

A 软管, 接头及设备

B 硬管接头及设备

C 快换接头

D 其他产品

DN 4-25

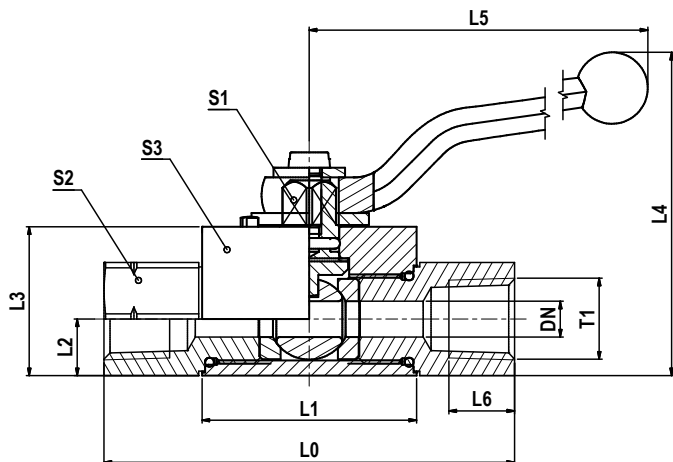

DN 32-50

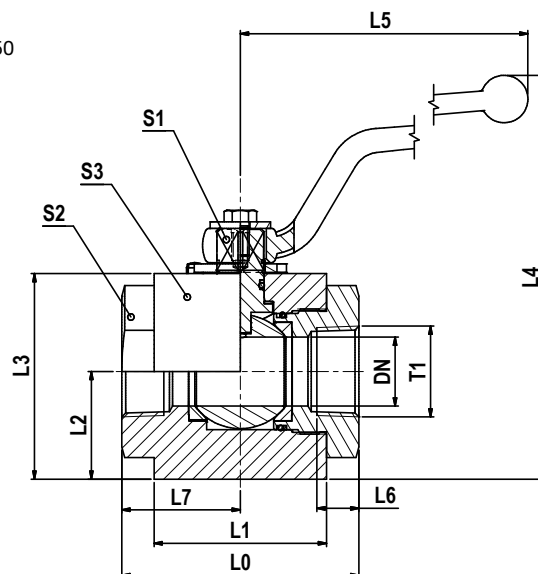

T1	DN	L0	L1	L2	L3	L4	L5	L6	L7	S1	S2	S3	重量 g/件	订货号	PN (bar)
1/8-27 NPT	5	69	36	9.5	25	55	76	7.0	-	7	19	20	225	KH1/8NPTCFX	500
1/4-18 NPT	6	69	36	9.5	25	55	76	11.0	-	7	19	20	210	KH1/4NPTCFX	500
3/8-18 NPT	10	73	45	14.5	35	68	100	11.5	-	8	24	30	430	KH3/8NPTCFX	500
1/2-14 NPT	13	82	51	17.0	40	93	113	15.0	-	10	30	35	670	KH1/2NPTCFX	500
3/4-14 NPT	20	93	60	24.0	55	120	171	16.0	-	14	41	45	1300	KH3/4NPTCFX	420
1-11.5 NPT	25	115	70	26.0	60	125	171	19.0	-	14	50	55	2000	KH1NPTCFX	420
1 1/4-11.5 NPT	32	110	80	49.5	95	188	228	19.5	55	17	60	Ø99	4888	KH11/4NPTCFX	420
1 1/2-11.5 NPT	40	114	82	54.5	105	198	228	19.5	57	17	75	Ø109	5590	KH11/2NPTCFX	420
2-11.5 NPT	50	133	100	62.0	120	212	306	22.0	65	17	85	Ø124	9220	KH2NPTCFX	420

订货示例:

碳钢, 无六价铬镀锌: KH1/8NPTCFX

注: 订货号不含螺母卡套

订货号后缀			
材质	表面处理	示例	标准密封
碳钢, 无六价铬镀锌	CF	KH1/8NPTCFX	POM / NBR

样本尺寸仅供参考, 请以实际产品尺寸为准。

# KH 2位2通NPT不锈钢球阀

NPT内螺纹 (SAE 476) / NPT 内螺纹 (SAE 476)

DN 4-25

DN 32-50

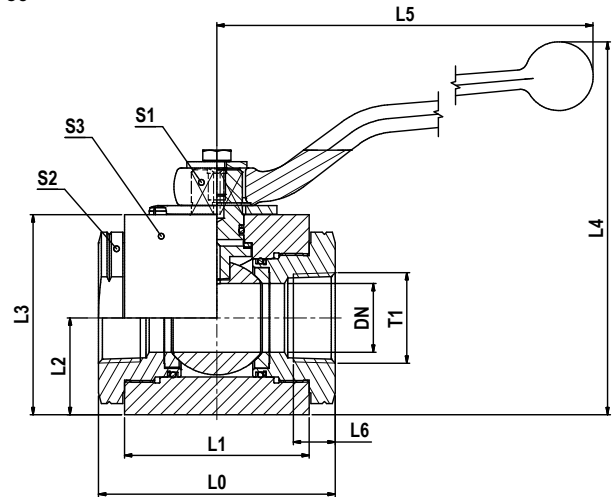
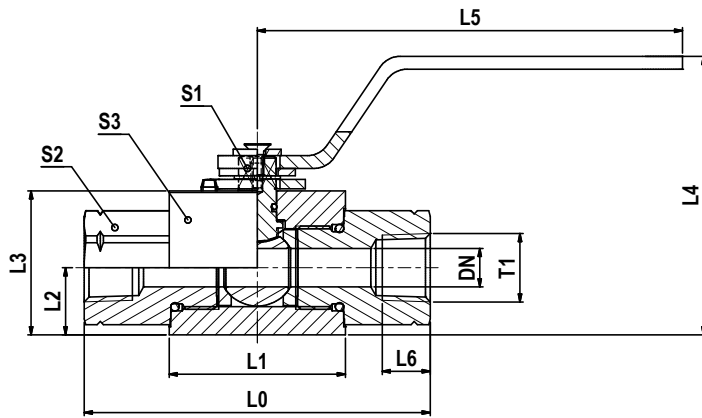

T1	DN	L0	L1	L2	L3	L4	L5	L6	S1	S2	S3	重量 g/件	订货号	PN (bar)
1/8-27 NPT	4	82	41.5	13.5	30.0	54	80.0	8.0	7	22	30	431	KH1/8NPT71X	500
1/4-18 NPT	6	82	41.5	13.5	30.0	54	80.0	11.5	7	22	30	436	KH1/4NPT71X	500
3/8-18 NPT	10	95	53.0	18.0	40.0	82	132.5	11.5	8	30	40	956	KH3/8NPT71X	500
1/2-14 NPT	12	108	55.0	21.0	45.0	87	132.5	15.0	10	32	45	1204	KH1/2NPT71X	500
3/4-14 NPT	20	111	65.0	31.0	65.0	118	190.0	16.0	14	46	65	2723	KH3/4NPT71X	400
1-11.5 NPT	25	122	71.0	38.0	75.0	128	190.0	19.0	14	50	75	3646	KH1NPT71X	400
1 1/4-11.5 NPT	32	110	86.0	45.0	93.0	174	320.0	19.5	19	70	Ø100	5887	KH11/4NPT71X	400
1 1/2-11.5 NPT	40	120	92.0	52.0	104.5	185	320.0	19.5	19	80	Ø110	7430	KH11/2NPT71X	400
2-11.5 NPT	50	140	97.0	59.5	119.5	201	320.0	25.0	19	95	Ø125	10100	KH2NPT71X	400

订货示例:

316Ti 不锈钢: KH1/8NPT71X

注: 订货号不含螺母卡套

订货号后缀			
材质	表面处理	示例	标准密封
碳钢, 无六价铬镀锌	71	KH1/8NPT71X	POM / NBR

样本尺寸仅供参考, 请以实际产品尺寸为准。

# KH 2位3通紧凑型碳钢球阀

EO24°锥 / EO24°锥 / EO24°锥

A 软管, 接头及设备

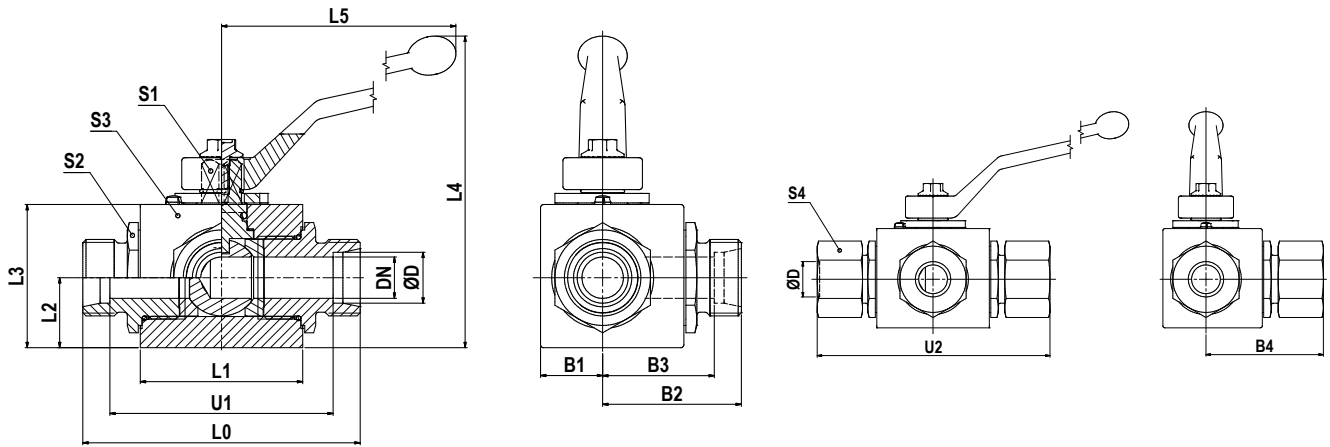

B 硬管接头及设备

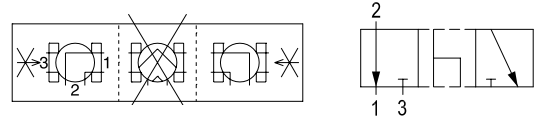

L-Version

C 快换接头

钢管系列	外径 DN	L0	L1	L2	L3	L4	L5	U1	U2	B1	B2	B3	B4	S1	S2	S3	S4	重量 g/件	Order code	PN (bar)	
L <sup>1)</sup>	06	4	67	36	14.5	30	59.5	76	53	82	12.0	33.5	26.5	41.0	7	19	30	14	320	KH3/2-06LCFX	500
	08	6	67	36	14.5	30	59.5	76	53	82	12.0	33.5	26.5	41.0	7	19	30	17	320	KH3/2-08LCFX	500
	10	8	75	45	14.5	35	67.5	100	61	90	17.5	37.5	30.5	45.0	8	24	40	19	550	KH3/2-10LCFX	500
	12	10	75	45	14.5	35	67.5	100	61	90	17.5	37.5	30.5	45.0	8	24	40	22	550	KH3/2-12LCFX	500
	15	13	83	51	22.0	45	98.0	113	69	99	19.5	41.5	34.5	49.5	10	30	45	27	890	KH3/2-15LCFX	500
	18	16	82	50	25.0	50	103.0	113	67	99	25.0	41.0	33.5	49.5	10	36	50	32	1050	KH3/2-18LCFX	400
	22	20	99	60	29.0	60	125.0	171	84	116	23.5	51.0	43.5	58.0	14	41	55	36	1610	KH3/2-22LCFX	400
	28	25	108	70	31.0	65	130.0	171	93	126	30.0	54.0	46.5	63.0	14	50	65	41	2270	KH3/2-28LCFX	400
	35	32/25	116	70	31.0	65	130.0	171	95	138	30.0	58.0	47.5	69.5	14	50	65	50	2480	KH3/2-35LDN25CFX	400
	42	40/25	121	70	31.0	65	130.0	171	99	144	30.0	60.5	49.5	71.5	14	55	65	60	2600	KH3/2-42LDN25CFX	400
S <sup>2)</sup>	08	5	73	36	14.5	30	54.5	76	59	88	12.0	36.5	29.5	44.0	7	19	30	19	350	KH3/2-08SCFX	500
	10	6	73	36	14.5	30	54.5	76	58	90	12.0	36.5	29.0	45.0	7	19	30	22	350	KH3/2-10SCFX	500
	12	8	77	45	14.5	35	67.5	100	62	94	17.5	38.5	31.0	47.0	8	24	40	24	570	KH3/2-12SCFX	500
	14	10	81	45	14.5	35	67.5	100	65	100	17.5	40.5	32.5	50.0	8	24	40	27	570	KH3/2-14SCFX	500
	16	13	87	51	22.0	45	98.0	113	70	106	19.5	43.5	35.0	53.0	10	30	45	30	910	KH3/2-16SCFX	500
	20	16	90	50	25.0	50	103.0	113	69	112	25.0	45.0	34.5	56.0	10	36	50	36	1120	KH3/2-20SCFX	400
	25	20	107	60	29.0	60	125.0	171	83	131	23.5	55.0	43.0	65.5	14	41	55	46	1720	KH3/2-25SCFX	400
	30	25	120	70	31.0	65	130.0	171	93	146	30.0	60.0	46.5	73.0	14	50	65	50	2440	KH3/2-30SCFX	400
	38	32/25	134	70	31.0	65	130.0	171	102	163	30.0	67.0	51.0	81.5	14	55	65	60	2950	KH3/2-38SDN25CFX	400

订货示例:

碳钢, 无六价铬镀锌: KH3/2-06LCFX

注: 订货号不含螺母卡套

D 其他产品

订货号后缀			
材质	表面处理	示例	标准密封
碳钢, 无六价铬镀锌	CF	KH3/2-06LCFX	POM / NBR

样本尺寸仅供参考, 请以实际产品尺寸为准。

## KH 2位3通紧凑型 BSPP 碳钢球阀

BSPP内螺纹 (ISO 1179) / BSPP内螺纹 (ISO 1179) / BSPP内螺纹 (ISO 1179)

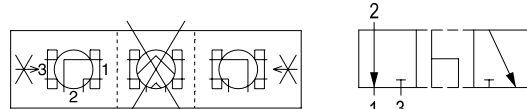
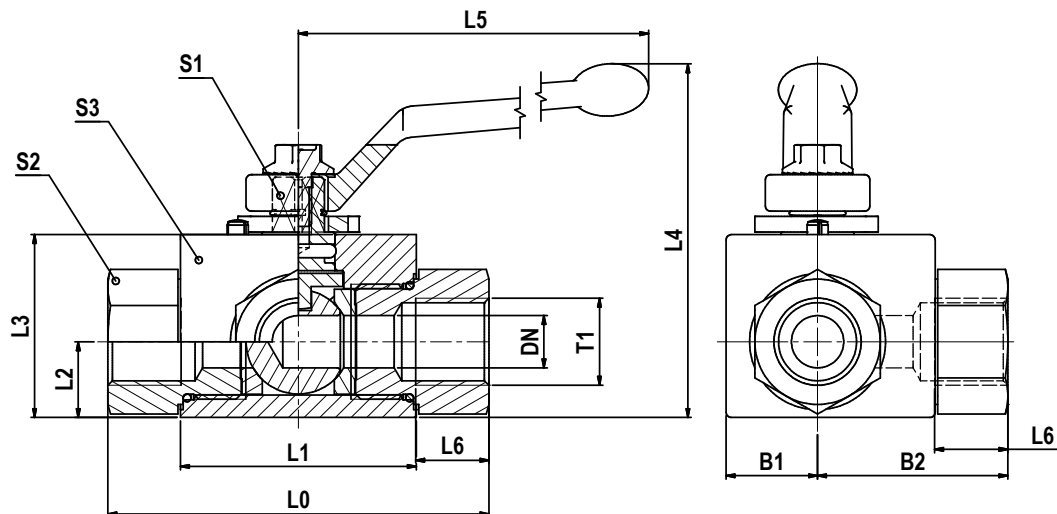

L-Version

T1	DN	L0	L1	L2	L3	L4	L5	L6	B1	B2	S1	S2	S3	Weight g/1 piece	Order code	PN (bar)
G 1/8	5	69	36	14.5	30	59.5	76	12	12.0	34.5	7	19	30	370	KH3/2-1/8CFX	500
G 1/4	6	69	36	14.5	30	59.5	76	12	12.0	34.5	7	19	30	340	KH3/2-1/4CFX	500
G 3/8	10	73	45	14.5	35	67.5	100	14	17.5	36.5	8	24	40	570	KH3/2-3/8CFX	500
G 1/2	13	82	51	22.0	45	98.0	113	15	19.5	41.0	10	30	45	940	KH3/2-1/2CFX	500
G 5/8	16	88	50	25.0	50	103.0	113	18	25.0	44.0	10	36	50	1240	KH3/2-5/8CFX	400
G 3/4	20	93	60	29.0	60	125.0	171	18	23.5	48.0	14	41	55	1720	KH3/2-3/4CFX	400
G 1	25	115	70	31.0	65	130.0	171	20	30.0	57.5	14	50	65	2650	KH3/2-1CFX	400
G 1 1/4	32/25	134	70	31.0	65	130.0	171	22	30.0	67.0	14	50	65	2710	KH3/2-11/4DN25CFX	400
G 1 1/2	40/25	139	70	31.0	65	130.0	171	24	30.0	69.5	14	55	65	2910	KH3/2-11/2DN25CFX	400

订货示例:

碳钢, 无六价铬镀锌: KH3/2-1/8CFX

注: 订货号不含螺母卡套

订货号后缀			
材质	表面处理	示例	标准密封
碳钢, 无六价铬镀锌	CF	KH3/2-1/8CFX	POM / NBR

样本尺寸仅供参考, 请以实际产品尺寸为准。

# VDHA 高压截止阀

EO 24°锥/EO 24°锥

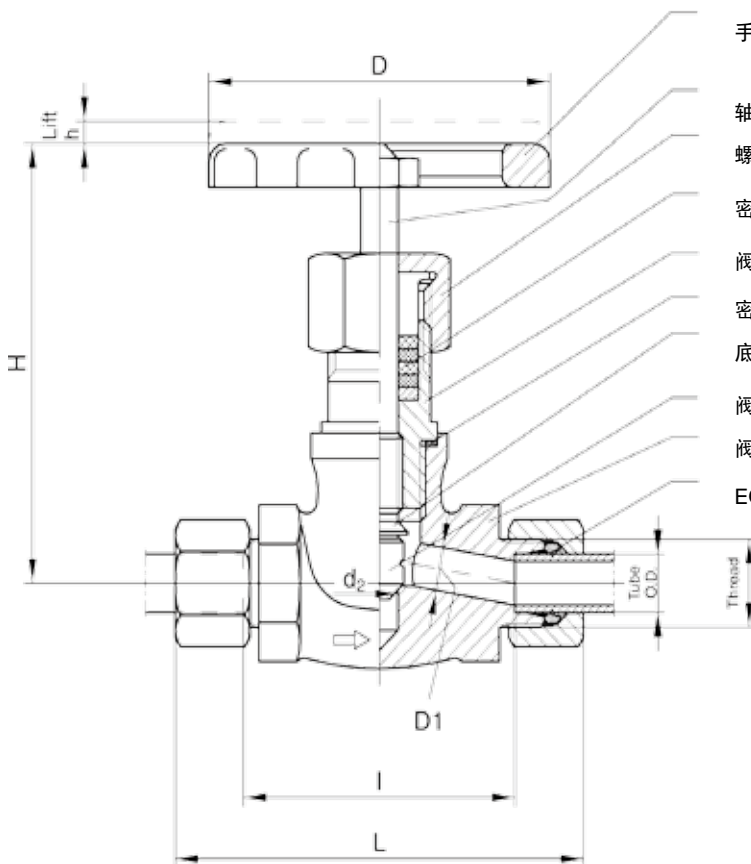

- 手轮 压铸铝, GD-AL Si 8 Cu 8
- 轴 不锈钢 1.4021
- 螺母 钢 1.0718
- 密封组件 GA24 (石墨)
- 阀头 不锈钢 1.0460
- 密封圈 阀头与阀体间密封
- 底部密封 靠底部接触密封
- 阀锥 可拆件, 不锈钢 1.4122
- 阀体 锻造不锈钢, 1.4104
- EO 卡套 连接钢管

最高可承受温度 400°C (50°C以上需要考虑压降影响)

压降表

温度	50°C	100°C	200°C	300°C	400°C
压降	6%	15%	37%	60%	84%

中间温度可采用插值法计算

锻造不锈钢阀体

安全设计系数1.5倍, 标准: DIN 3230 T5及ISO 5208

注: 截止阀承受的最大压力同时要参考EO端连接压力要求

应用: 水, 蒸汽, 矿物油, 液压油, 压缩空气 (不超过 50°C), 腐蚀性介质, 防火液体等

系列	钢管 外径	PN (bar)	DN	螺纹	d2	H	L	l	h	D	重量 g/件	带螺母卡套	
												EO-2	PSR 碳钢
S	06	630	4	M 14x1.5	9.5	120	95	66	6	100	891	VDHA06ZS	VDHA06S
	08	630	5	M 16x1.5	9.5	120	95	66	6	100	917	VDHA08ZS	VDHA08S
	10	630	7	M 18x1.5	9.5	120	97	65	6	100	937	VDHA10ZS	VDHA10S
	12	630	8	M 20x1.5	9.5	120	97	65	6	100	940	VDHA12ZS	VDHA12S
	14	630	10	M 22x1.5	9.5	120	119	84	6	100	1194	VDHA14ZS	VDHA14S
	16	400	11	M 24x1.5	9.5	120	119	83	6	100	1209	VDHA16ZS	VDHA16S
	20	400	13	M 30x2.0	11.0	120	122	79	6	100	1292	VDHA20ZS	VDHA20S
	25	400	17	M 36x2.0	12.0	143	154	106	9	125	2013	VDHA25ZS	VDHA25S
	30	250	19	M 42x2.0	22.5	164	156	103	12	125	2596	VDHA30ZS	VDHA30S
	38	250	25	M 52x2.0	26.5	198	179	118	12	180	4972	VDHA38ZS	VDHA38S

样本尺寸仅供参考, 请以实际产品尺寸为准。

软管, 接头及设备

A

B 硬管接头及设备

B

C 快换接头

C

D 其他产品

D

## WV 管路梭阀

EO24°锥 / EO24°锥 / EQ 24° 锥

该阀只允许流体通过 1 号或 2 号入口中的一个流向出口，同时封闭另一个入口。  
封闭入口是通过一个受流体压力作用移动的浮动滚珠实现的。

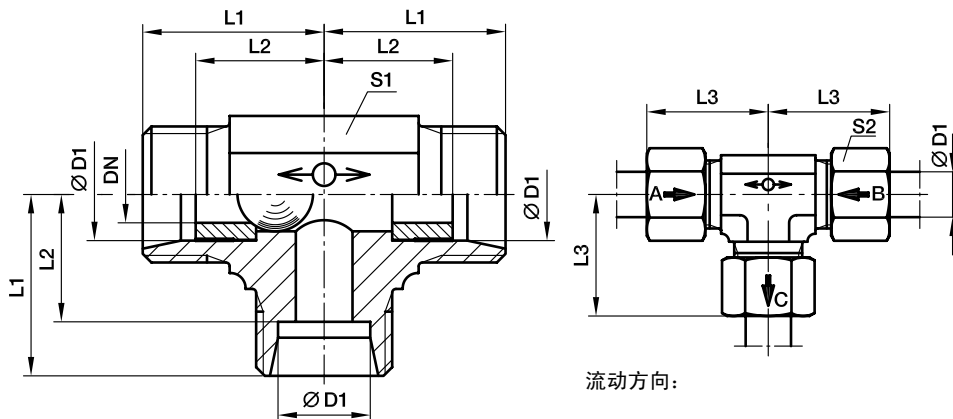

流动方向:

$D_1 \rightarrow D_3 = D_2$  关闭  
 $D_2 \rightarrow D_3 = D_1$  关闭

材料: 碳钢

成品表面: 无六价铬镀锌 Cr(VI)-free.

该阀不推荐用于压缩空气和其他气体。

WV 阀不可与焊接接头, 旋转螺母等无法与内锥定位台阶接触的接头连接

无压降的温度范围:  $-40^{\circ}\text{C}$  至  $+120^{\circ}\text{C}$ .

推荐的接头状态如图所示.

梭阀液压测试的泄漏量

$P_{\max}$ : 大约 20 滴 (测试周期 1 分钟).

系列	钢管外径		DN	L1	L2	L3	S1	S2	重量 g/件	订货号	PN (bar) CF
	D1	T1									
L	8	M 14x1.5	4.5	21	14	29	14	17	53	WV08LOMD	160
	10	M 16x1.5	6.0	22	15	30	17	19	73	WV10LOMD	160
	12	M 18x1.5	7.5	24	17	32	19	22	96	WV12LOMD	160
	15	M 22x1.5	10.0	28	21	36	19	27	134	WV15LOMD	160

订货示例:

碳钢, 无六价铬镀锌: WV12LOMDCF

注: 订货号不含螺母卡套

## ELA 排气阀

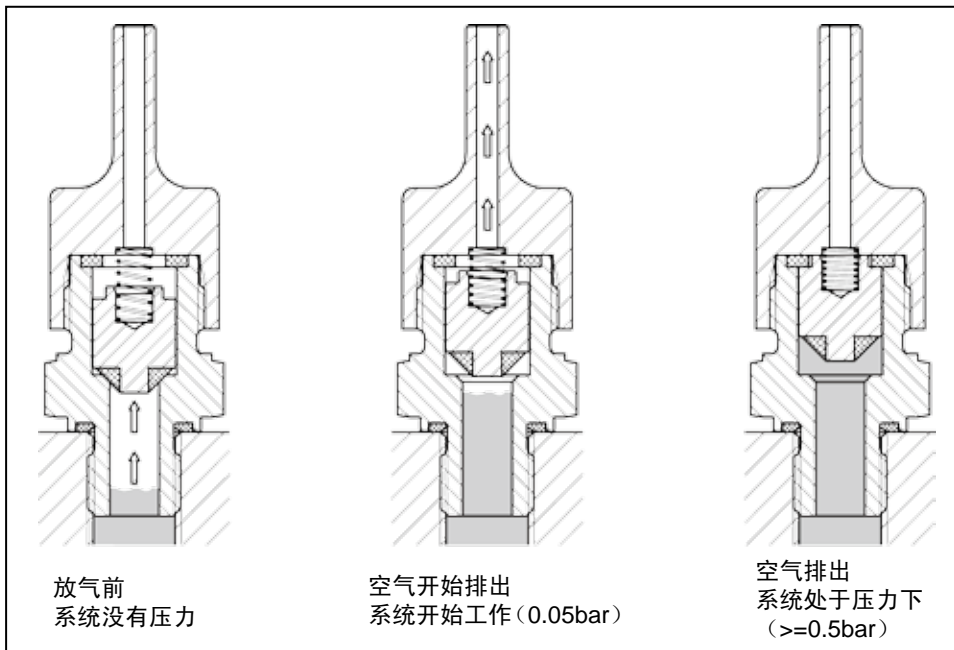

液压系统可使用排气阀有效排气。

系统可立即响应，压力介质的气体杂质不会导致控制失误。节省成本，省去停机排气时间。

- 易于安装
- 免维护
- 几乎无限的使用寿命
- 简单
- 安全
- 高效

放气区间:

- 开启压力 0.05 bar
- 关闭压力 0.5 bar

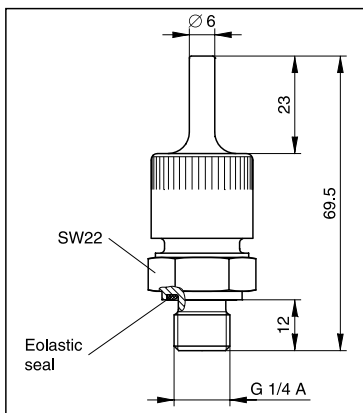

### BSPB 外螺纹带 ED 密封

PN(bar)	碳钢 ED密封	重量 g/件
400	ELA1/4EDCF	109

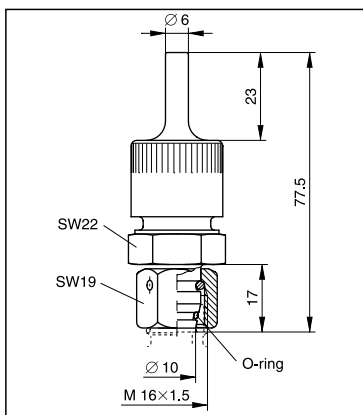

### EO24°锥旋转螺母

PN (bar)	碳钢 24°锥DKO	重量 g/件
315	ELAE10LCF	125

软管, 接头及设备

A

硬管接头及设备

B

快换接头

C

其他产品

D